

Installation Instructions

Models D-100
E-100



WARNING!!!

Post safety warning and barricade work area, at dock level and ground level to prevent unauthorized use of the dock position while service work is being performed.

Parts List

- 1 Head pad 2 Side pads

Hardware (D100)

- 9 Angle Bracket
 9 Flat bracket
 18-3/8" x 1 7/8" sleeve anchors
 36 - #14 x 1 1/2" wood screws

Hardware (E100)

- 6 Angle bracket
 7 Flat bracket
 13- 3/8" x 1 7/8" sleeve anchors
 26 - #14 x 1 1/2" wood screws

Instructions:

1. Marking and mounting locations for side pads.

Measure one half of the head pad length. From the centre line of the door opening (top & bottom) mark out the location of the outside of the side pads as shown in **Figure 1**. Repeat for the other side pad location.

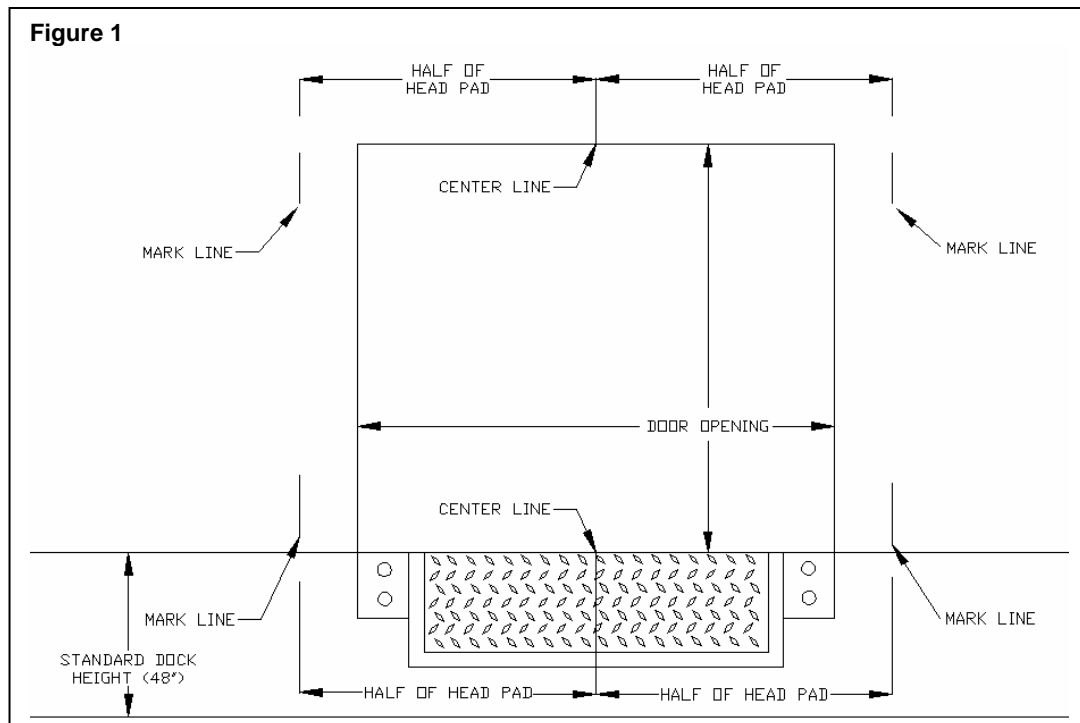

2. Attaching the brackets to the side pads.

Fasten the angle brackets to the inside edge of the side pads as shown in **Figure 2** using two(2) #14 x 1.5" wood screws for each bracket. Repeat on outside edge of the side pads with flat brackets. Position the brackets so they line up with the mortar joints on block walls.

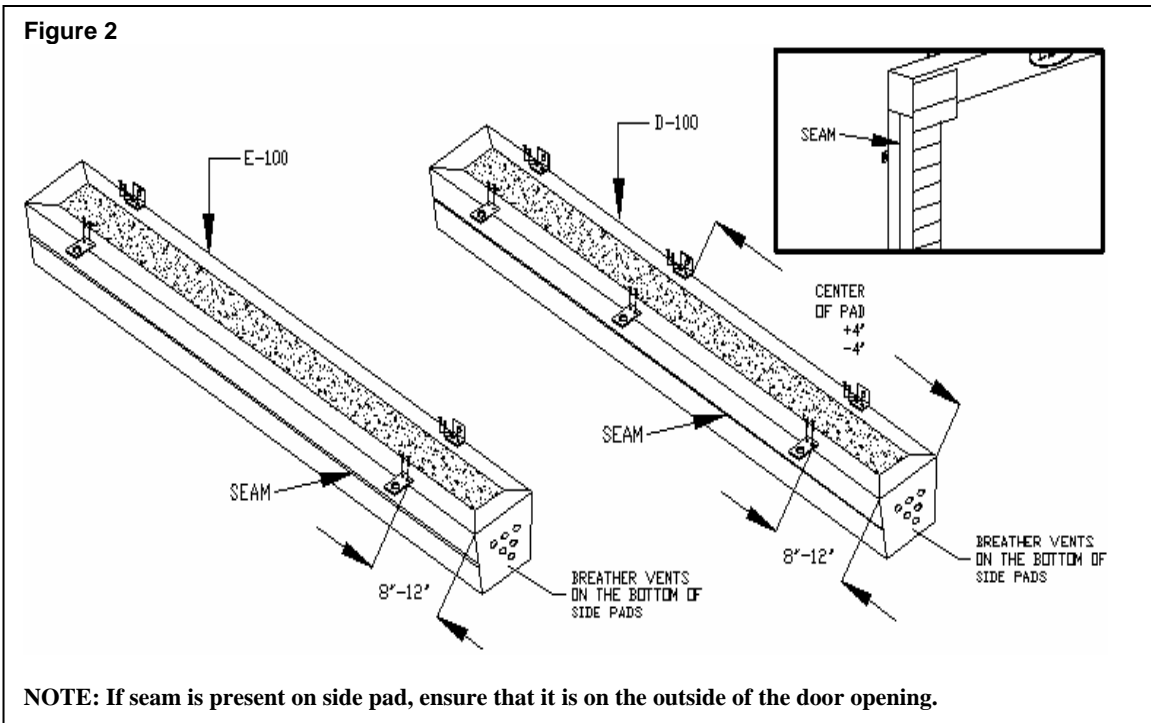

3. Mounting the side pads.

Place one vertical pad in place lining up the outside edge of the side pads with the marks as shown in **Figure 3**. Ensure that the side pads are plumb and sit flush with the building wall. Fasten to building wall using 3/8" x 1-7/8" sleeve anchors supplied. Repeat steps 2 & 3 for the other side pad.

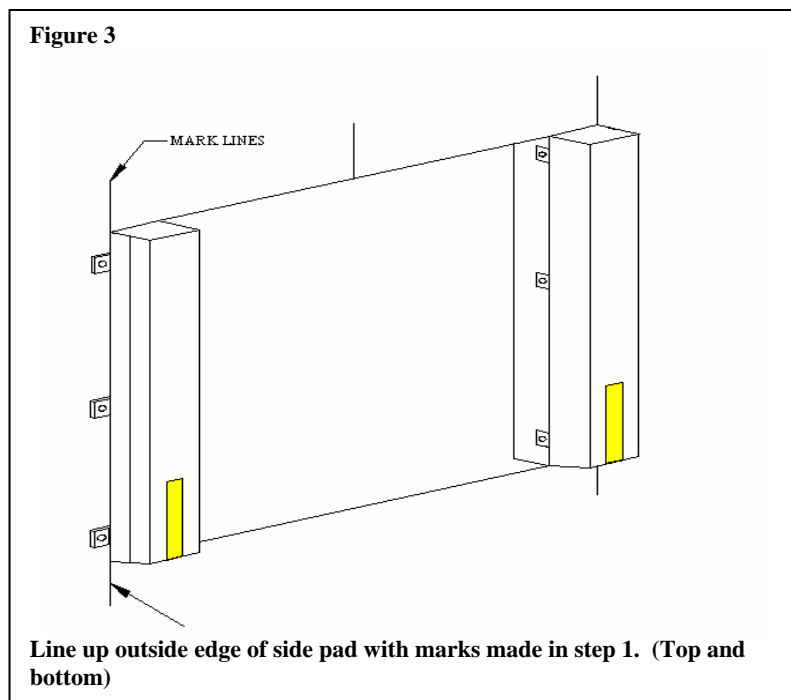

4. Attaching the brackets to the head pad.

Fasten the angle brackets to inside edge of the head pad as shown in **Figure 4** using two #14 x 1.5" wood screws for each bracket. Repeat on outside edge of head pad for flat brackets. Position the brackets so that they line up with the mortar joints on block wall.

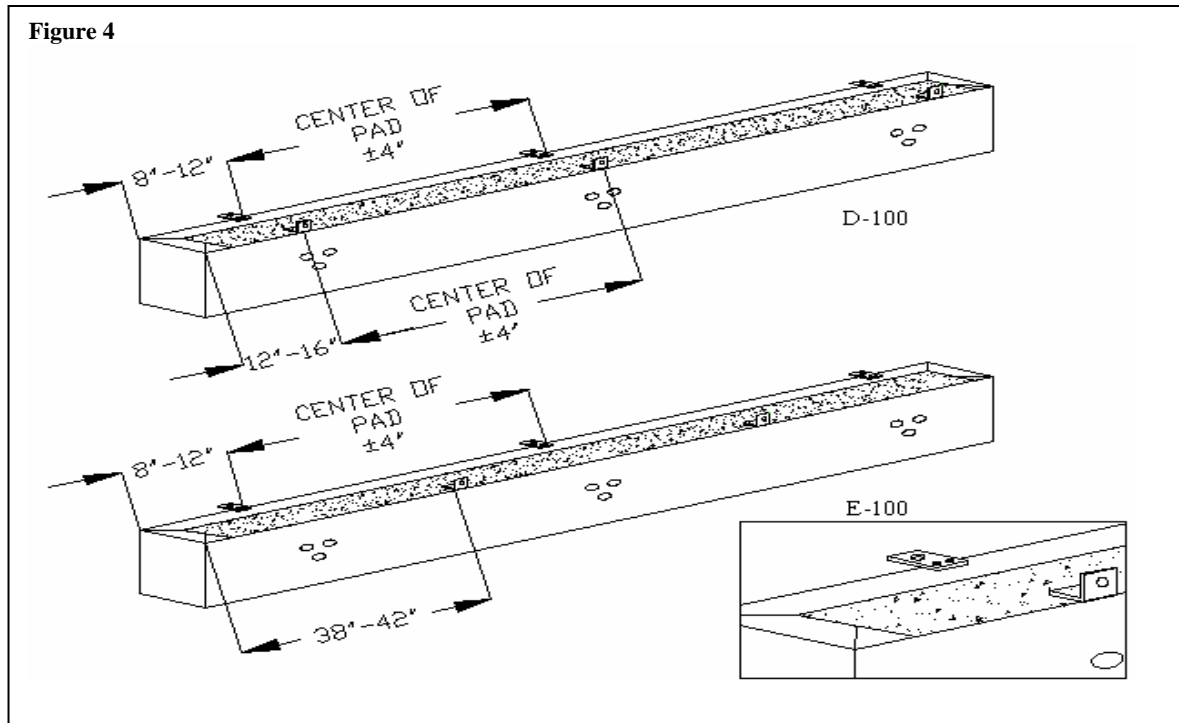

5. Mounting the head pad.

Place the head pad on top of the side pads as shown in **Figure 5**. Head pad should sit flush with the outside edge of both side pads. Fasten to the building wall using 3/8" x 1-7/8" sleeve anchors supplied.

6. Caulking.

Caulk across the top of the head pad using a good quality caulking.

7. Clean up around dock area when complete.

